

# NEWS from CPSC

## U.S. Consumer Product Safety Commission

Office of Information and Public Affairs

Washington, DC 20207

FOR IMMEDIATE RELEASE

June 12, 2008

Release #08-303

**Firm's Recall Hotline: (877) 472-0007**

CPSC Recall Hotline: (800) 638-2772

CPSC Media Contact: (301) 504-7908

### Robert Bosch Tool Corp. Recalls Hammer Drills Due to Risk of Injury

WASHINGTON, D.C. - The U.S. Consumer Product Safety Commission, in cooperation with the firm named below, today announced a voluntary recall of the following consumer product. Consumers should stop using recalled products immediately unless otherwise instructed.

**Name of Product:** Bosch Hammer Drills

**Units:** About 9,700

**Manufacturer:** Robert Bosch Tool Corp., of Mount Prospect, Ill.

**Hazard:** The drill can continue to operate after the trigger has been released, posing a risk of injury to consumers.

**Incidents/Injuries:** None reported.

**Description:** The recalled hammer drill is blue with "BOSCH" printed on the side. The model number 1191VSR can be located on the product nameplate mounted on the side of the motor. The product's packaging will be marked as 1191VSRK (the "K" indicates that the hammer drill was packaged with a case in a kit). Only drills with a serial number that begins with "7" are included in the recall.

**Sold at:** Menards and other hardware retailers and industrial distributors nationwide from July 2007 through April 2008 for about \$100.

**Manufactured in:** Malaysia

**Remedy:** Consumers should stop using the recalled hammer drill immediately and contact the firm for a free repair.

**Consumer Contact:** For additional information, contact the Robert Bosch Tool Corp. toll-free at (877) 472-0007 between 7 a.m. and 7 p.m. CT Monday through Friday, or visit the firm's Web site at [www.boschtools.com](http://www.boschtools.com)

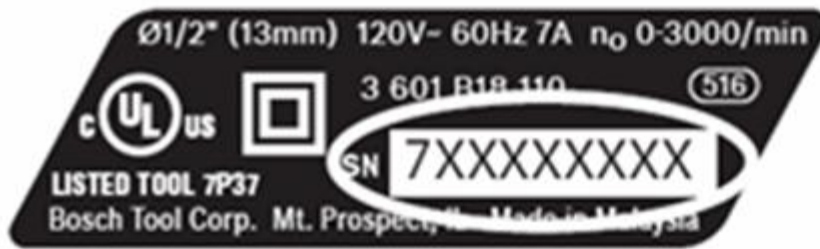

SERIAL NUMBER

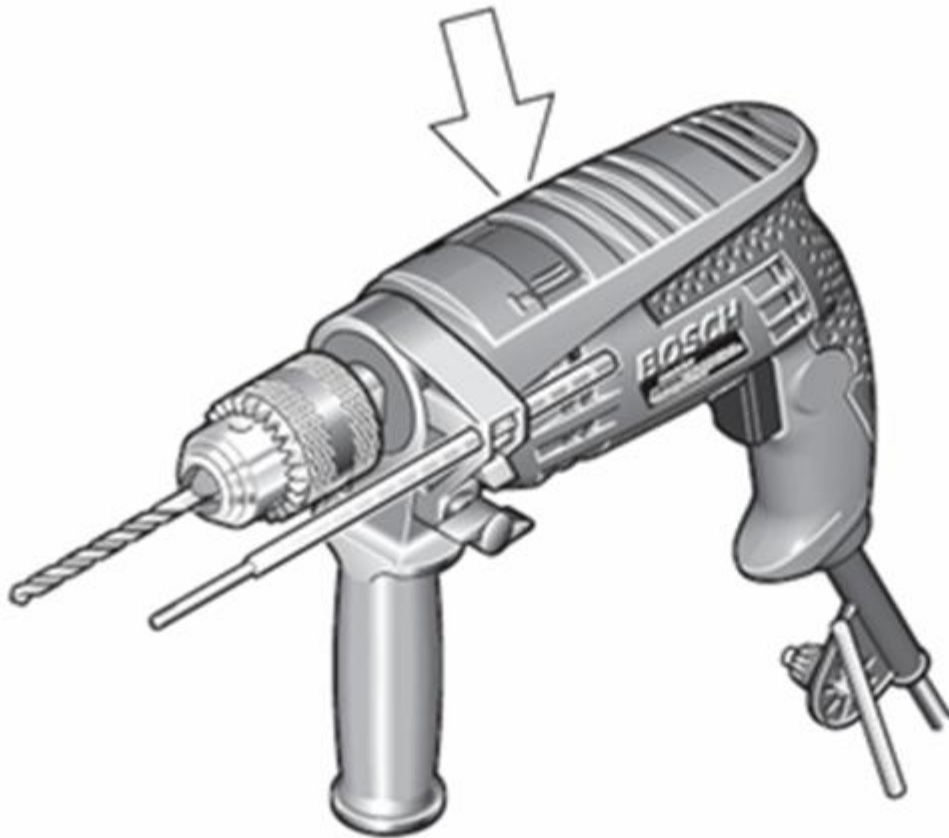

---

[Send the link for this page to a friend!](#) The U.S. Consumer Product Safety Commission is charged with protecting the public from unreasonable risks of serious injury or death from more than 15,000 types of consumer products under the agency's jurisdiction. Deaths, injuries and property damage from consumer product incidents cost the nation more than \$800 billion annually. The CPSC is committed to protecting consumers and families from products that pose a fire, electrical, chemical, or mechanical hazard. The CPSC's work to ensure the safety of consumer products - such as toys, cribs, power tools, cigarette lighters, and household chemicals - contributed significantly to the decline in the rate of deaths and injuries associated with consumer products over the past 30 years.

To report a dangerous product or a product-related injury, call CPSC's hotline at (800) 638-2772 or CPSC's teletypewriter at (800) 638-8270, or visit CPSC's web site at [www.cpsc.gov/talk.html](http://www.cpsc.gov/talk.html). To join a CPSC email subscription list, please go to <https://www.cpsc.gov/cpsclist.aspx>. Consumers can obtain this release and recall information at CPSC's Web site at [www.cpsc.gov](http://www.cpsc.gov).

